



# ADDAX<sup>®</sup> COMPOSITE COUPLINGS

INCH/METRIC



**Table Of Contents**

<b>DESCRIPTION</b>	<b>PAGE</b>
Rexnord® Addax Composite Cooling Tower Coupling .....	.3
Rexnord Addax Composite Center Section .....	.4
Rexnord Addax Patented Composite Flexible Element.....	.5
Rexnord Addax Patented Continuous Fiber Composite Flange .....	.5
 <b>COUPLING SELECTION AND DIMENSIONS</b>	
Cooling Tower Coupling Application Data Sheet .....	.6
Coupling Models and Dimensions .....	.7, 8
 <b>OPTIONS AND TECHNICAL DATA</b>	
Rexnord Cooling Tower Backstop .....	.9
Addax Cooling Tower Brake .....	.9
Engineering Data.....	.10

# Rexnord Addax Composite Cooling Tower Coupling

## Cooling Tower Coupling Solutions

Rexnord pioneered and introduced the first advanced composite couplings to the cooling tower industry in 1987. With over 50,000 Rexnord Addax composite couplings installed on every continent around the world over the past 25 years, Rexnord has the most experience of any composite cooling tower manufacturer.

The Rexnord Addax Composite Cooling Tower Coupling delivers the best value for the cooling tower industry by providing excellent features such as:

- Corrosion resistance
- High-misalignment capacity
- Excellent fatigue resistance
- Low weight
- Ease of installation

**Choose a Rexnord Addax Composite Coupling as your cooling tower coupling if you are currently using a steel coupling or an alternative composite coupling.**

## Service & Support

Rexnord is the largest coupling manufacturer in the world and has the most comprehensive global sales and customer service team in the industry. Rexnord associates are experts in cooling tower coupling applications and are available to assist you 24/7 if an emergency arises.

## Lead Time

Virtually every cooling tower coupling installation has unique coupling dimensions, therefore all Rexnord Addax coupling assemblies are “made to order” per customer-supplied specifications. Even though each Rexnord Addax coupling is custom-made, Rexnord provides the absolute best standard lead time in the cooling tower industry — two weeks after receipt of order. As an added benefit, Rexnord offers an exclusive emergency expediting option that includes:

- Same day shipment
- Three-day shipments
- Five-day shipments

## Quality

Our associates are continually improving our products by applying *Lean Manufacturing and Six Sigma* methodology to add increased value to our products. Upon request, a certificate of material, certificate of balance and certificate of conformity can be provided for every Rexnord Addax coupling.

## Price

The Rexnord Addax Composite Cooling Tower Coupling is the most inexpensive product of its kind, while providing the most comprehensive list of product features and benefits. Combine the price and product features with Rexnord’s dedicated associates who provide an unprecedented level of service and support, and you will agree that the Rexnord Addax Coupling delivers the best value.

## Why choose a Rexnord Addax Composite Cooling Tower Coupling over the alternatives?

Features, Functions, Benefits of Rexnord Addax Cooling Tower Coupling		
Features	Functions	Benefits
Low weight	Reduced mass Reduced bearing loads Reduced inertia	Simplify installation Increase bearing life Reduce vibration
Corrosion resistance	Chemical attack resistance	Extend service life Reduce maintenance Increase safety Achieve low cost of ownership
Low coefficient of thermal expansion	Dimensional stability	Reduce vibration Reduce stresses Increase operating range
Continuous fiber composite spacer flange	Infinite fatigue life	Achieve low cost of ownership
Unitized flex element	Elimination of fretting infinite fatigue life simplified installation	Achieve low cost of ownership Prolong service life Reduce maintenance Increase safety
High-misalignment capacity	Reduced equipment stress Increased life	Make installation easier Reduce ownership costs
High strength to weight ratio	Increased stiffness Higher critical speed	Eliminate harmonics Eliminate steady bearings

## Rexnord Addax Composite Center Section

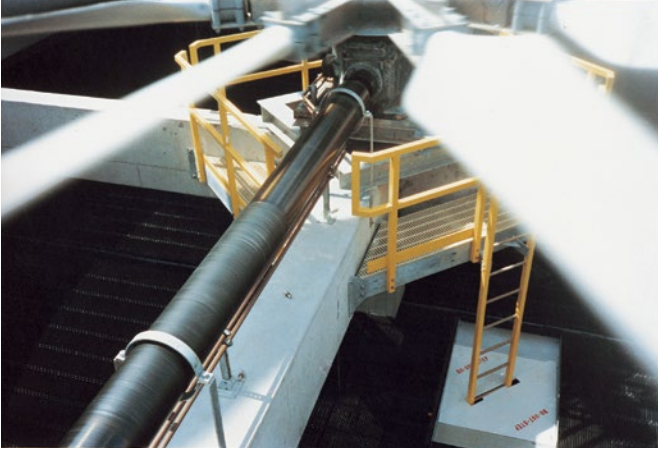

The advanced composite, full-floating center section weighs less than 25% of a comparable steel spacer. But don't be fooled by the lighter weight. Rexnord Addax advanced composites are heavyweights when it comes to performance, due to their rugged, corrosion-resistant design. With almost twice the critical speed of metals, and up to an 80% reduction in overhung bearing loads, Rexnord Addax composite couplings reduce vibration and extend bearing life. Installation is made easier because there is no need for a crane to install most Rexnord Addax advanced composite coupling systems. Most cooling tower coupling assemblies weigh less than 100 pounds, so maintenance personnel can easily handle them.

The specific modulus of the composite material is 3.5 to 5 times that of steel alloys. This allows the composite spacers to span almost twice the distance of a comparable metal spacer without the need for intermediate bearings. The lower density and higher specific stiffness of composite materials make it practical to use larger cylinder diameters than would be feasible with steel.

A single-length, 20-foot long composite drive shaft from a Rexnord Addax coupling may weigh 100 pounds while the steel counterpart would weigh about 500 pounds and be in two sections. Elimination of steady bearings means drastically reduced maintenance requirements, at lower cost of ownership and increased reliability.

Standard corrosion resistance exceeds that of 316ss; or Rexnord Addax associates can formulate corrosion resistance for specific conditions. Additional ultraviolet light protection is provided by a carbon black additive.

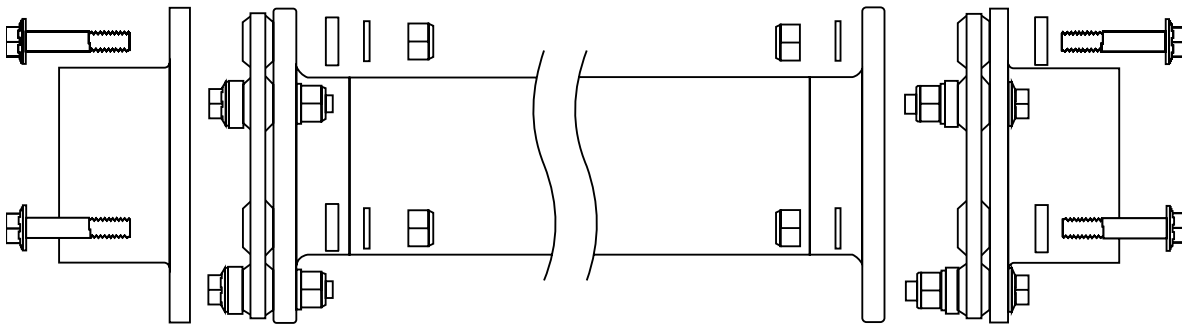

*Addax Composite Coupling*

## Rexnord Addax Patented Composite Flexible Element

This patented Rexnord Addax flexible element was developed to withstand harsh conditions and high-misalignment problems found in cooling towers. This flexible element is a unitized disc constructed of advanced composite material and stainless steel bushings. All flex elements are encapsulated in urethane for ease of handling, appearance, and to prevent fretting and corrosion.

- High-strength composite appearance, and to prevent fretting and corrosion.
- Designed for severe conditions The exceptional physical and mechanical properties of continuous fiber provides high-misalignment capacity and long service life. Rexnord Addax flexible elements provide infinite fatigue life and simplified installation.
- One-degree misalignment per flexible element
- Exceptional service life
- No fretting and corrosion effects



Fretting and stress crack corrosion — the leading contributors to metal disc pack failure — are completely eliminated along with the multitude of parts required for assembly. Maintenance costs are dramatically reduced and installation is greatly simplified. Rexnord Addax flexible elements provide years of trouble-free operation, even under the most demanding conditions.

Rexnord Addax elements are offered in a number of sizes with different torque ratings. Each torque rating is based on static and dynamic tests to provide an infinite fatigue life at rated torque and misalignment.

The flexible element is the only component of the coupling system that experiences alternating loading in which fatigue becomes a factor. The strength of graphite/epoxy remains well over 100,000 psi through infinite cycles. Therefore, the Rexnord Addax flexible element has theoretical infinite fatigue life under rated operating conditions.

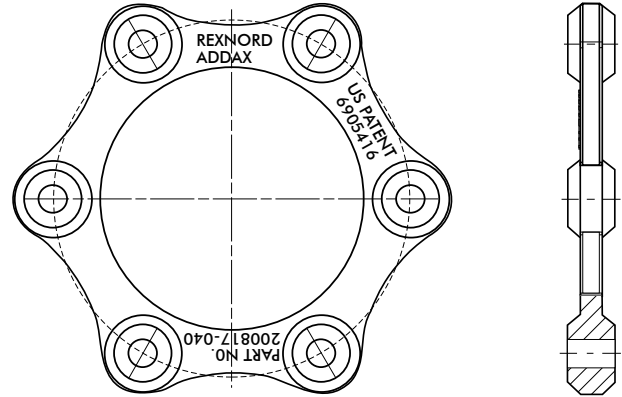

## Rexnord Addax Patented Continuous Fiber Composite Flange

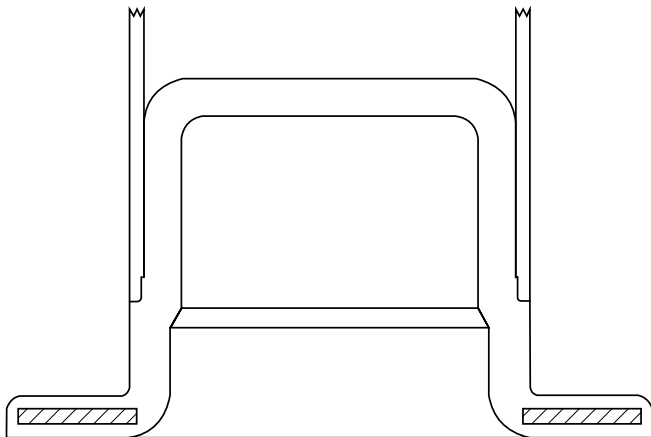

Patent No. 5724715

The Rexnord Addax coupling flange is an integral component of the Rexnord Addax coupling. This patented component transfers torque from the flexible element to the long span composite tube. It is a low-mass, all-composite structure fabricated from continuous fiber material. There is no metal in it at all. The fiber angle path has been optimized for carrying torque and minimizing stress through the flange. This design offers supreme fatigue strength for cooling tower operation. It also offers extraordinary corrosion resistance in a chlorine-rich cooling tower environment.

One of the design features is a high-fiber-volume composite reinforcing ring (cross hatched area) designed integral into the flange area. This ring provides additional strength and stiffness in the bolt joint area. This strength in the flange provides the highest integrity for the bolt circle attaching and centering the flexible element.

Other manufacturers fabricate this flange from random fiber glass and do not have the fatigue strength of the Addax coupling flange. A random fiber flange does not have the reinforcing ring and is prone to fatigue failure in the grueling cooling tower duty applications. The Rexnord Addax coupling flange is continuous fiber and fatigue-tested to demonstrate superior strength.

# Cooling Tower Coupling Application Data Sheet

Quote/Job Number: \_\_\_\_\_ Date: \_\_\_\_\_

Customer: \_\_\_\_\_ Location: \_\_\_\_\_

DBSE: \_\_\_\_\_ Quantity: \_\_\_\_\_

**NOTE:** Distance Between Shaft Ends (DBSE) is defined as the length measured between the face of the gear box input shaft and the face of the motor shaft to within  $\pm .10$  inches ( $\pm 2.5$  mm).

**Motor Data:**

Horsepower: \_\_\_\_\_

RPM: \_\_\_\_\_

NEMA or IEC Frame Size: \_\_\_\_\_

Motor Shaft Diameter: \_\_\_\_\_

Key Size: \_\_\_\_\_

Two Speed:            **Yes**        **No**        **High Speed:** \_\_\_\_\_        **Low Speed:** \_\_\_\_\_

Variable Speed:      **Yes**        **No**        **Max Speed:** \_\_\_\_\_        **Min Speed:** \_\_\_\_\_

**Gear Reducer Data:**

Reduction Ratio: \_\_\_\_\_

Input Shaft Diameter: \_\_\_\_\_

Key Size: \_\_\_\_\_

**Fan Data:**

Number of Blades: \_\_\_\_\_

Fan RPM: \_\_\_\_\_

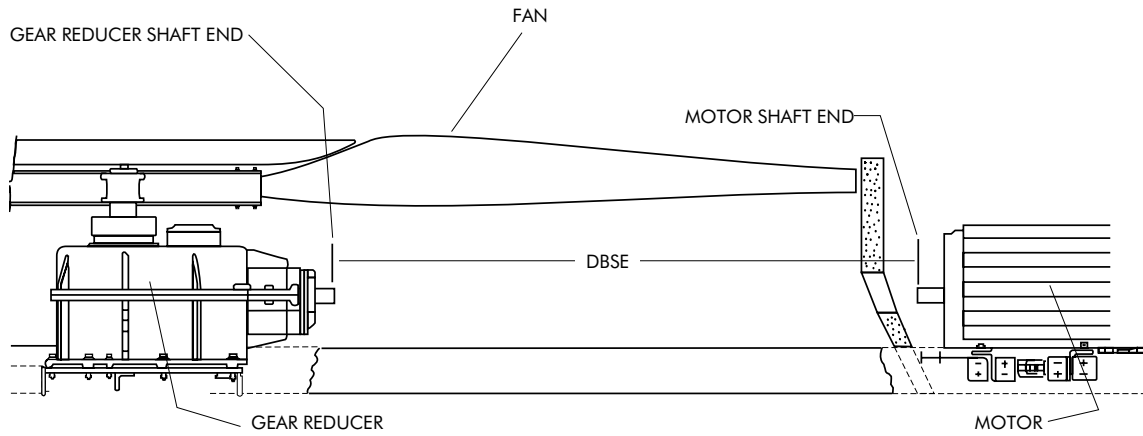

# Coupling Models and Dimensions

## Specification

### Rexnord Addax Coupling

Standard construction consists of a flanged composite spacer, patented composite flexible elements, 316 Stainless Steel hubs and 316 Stainless Steel hardware. K-500 Monel hardware is available upon request to suit corrosive environments.

### Standard Balance

All couplings are dynamically balanced to meet ANSI/AGMA 9000-C90 (R96), Class 9 specifications.

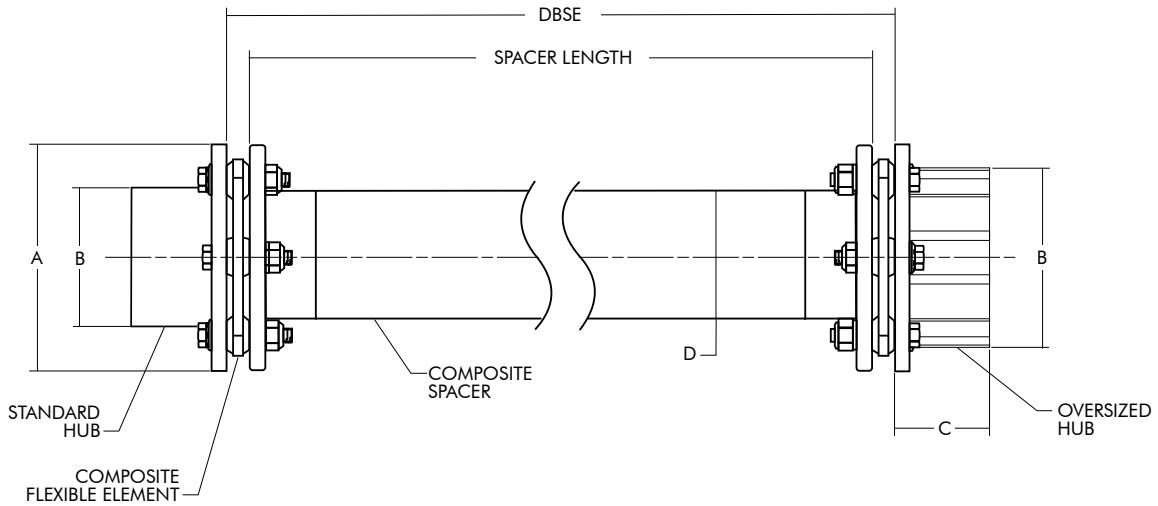

**Models: 350.275, 375.275, 450.275, 485.338, 650.425, 850.625**

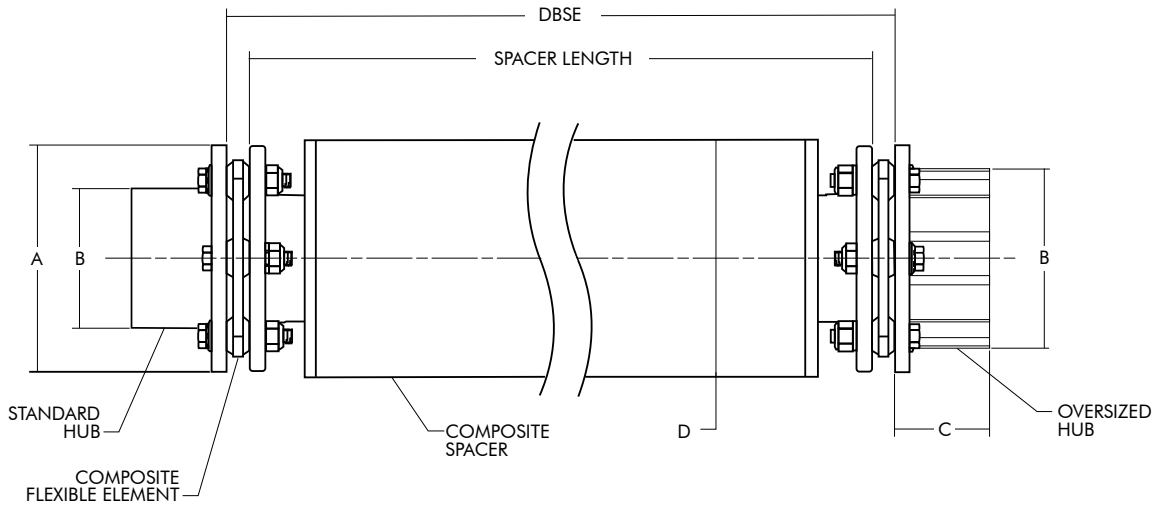

**Models: 485.425, 650.625, 650.825, 850.825, 850.1025, 850.1275**

# Coupling Models and Dimensions

## General Dimensions (in / mm) <sup>①</sup>

Model Series	Spacer & Flange Material <sup>②</sup>	Max DBSE @ 1780 RPM @ 1.15 S.F.	Max DBSE @ 1480 RPM @ 1.15 S.F.	Max Bore		A	B		C		D	Min DBSE	Min Bore
				Standard <sup>③</sup>	Oversized		Standard	Oversized	Standard <sup>③</sup>	Oversized			
350.275	F	95 / 2413	106 / 2692	2.13 / 55	2.38 / 65	5.25 / 133	3.06 / 78	4.00 / 102	1.81 / 46	2.6 / 66	2.75 / 70	5.4 / 137	0.63 / 16
	A	107 / 2718	119 / 3023										
	R	114 / 2896	126 / 3200										
375.275	F	95 / 2413	106 / 2692	2.13 / 55	2.38 / 65	5.25 / 133	3.06 / 78	4.00 / 102	1.81 / 46	2.6 / 66	2.75 / 70	5.4 / 137	
	A	107 / 2718	119 / 3023										
	R	114 / 2896	126 / 3200										
450.275	F	95 / 2413	106 / 2692	2.13 / 55	2.88 / 75	5.25 / 133	3.15 / 80	4.00 / 102	1.81 / 46	2.63 / 67	2.75 / 70	5.4 / 137	
	A	107 / 2718	119 / 3023										
	R	114 / 2896	126 / 3200										
	X	128 / 3251	141 / 3581										
485.338	F	100 / 2540	113 / 2870	2.63 / 70	3.38 / 85	6.00 / 152	3.72 / 94	4.75 / 121	2.50 / 64	2.75 / 70	3.38 / 86	8.0 / 203	
	A	116 / 2946	127 / 3226										
	R	127 / 3226	140 / 3556										
485.425	R	141 / 3581	154 / 3912	2.63 / 70	3.38 / 85	6.00 / 152	3.72 / 94	4.75 / 121	2.50 / 64	2.75 / 70	4.25 / 108	8.0 / 203	
	X	154 / 3912	169 / 4293										
485.625	R	170 / 4318	189 / 4800	2.63 / 70	3.38 / 85	6.00 / 152	3.72 / 94	4.75 / 121	2.50 / 64	2.75 / 70	6.25 / 159	9.5 / 241	
	A	133 / 3378	148 / 3759										
	R	141 / 3581	154 / 3912										
650.425	X	154 / 3912	169 / 4293	3.00 / 80	3.88 / 100	6.75 / 171	4.25 / 108	5.25 / 133	2.56 / 65	2.75 / 70	4.25 / 108	6 / 152	
	R	170 / 4318	189 / 4800										
	X	186 / 4725	208 / 5283										
650.625	R	193 / 4902	215 / 5461	3.00 / 80	3.88 / 100	6.75 / 171	4.25 / 108	5.25 / 133	2.56 / 65	2.75 / 70	6.25 / 159	9.5 / 241	
	X	209 / 5309	232 / 5893										
	R	170 / 4318	189 / 4800										
650.825	X	209 / 5309	232 / 5893	3.00 / 80	3.88 / 100	6.75 / 171	4.25 / 108	5.25 / 133	2.56 / 65	2.75 / 70	8.25 / 210	14.2 / 361	
	A	157 / 3988	172 / 4369										
	R	170 / 4318	189 / 4800										
850.625	X	186 / 4725	208 / 5283	a) 3.13 / 75 b) 4.13 / 105	5.06 / 130	9.0 / 229	5.8 / 147	7.5 / 191	a) 2.51 / 64 b) 3.31 / 84.1	2.50 / 64	6.25 / 159	14.2 / 361	
	R	193 / 4902	215 / 5461										
	X	209 / 5309	232 / 5893										
850.825	X	229 / 5817	253 / 6426	a) 3.13 / 75 b) 4.13 / 105	5.06 / 130	9.0 / 229	5.8 / 147	7.5 / 191	a) 2.51 / 64 b) 3.31 / 84.1	2.50 / 64	10.25 / 260	1.00 / 25	
	X	245 / 6223	275 / 6985										
850.1025	X	229 / 5817	253 / 6426								12.75 / 324		
850.1275	X	245 / 6223	275 / 6985								12.75 / 324		

Model Series	Spacer & Flange Material <sup>②</sup>	Weight @ Min DBSE (lb / kg)	WR <sup>2</sup> @ Min DBSE <sup>④</sup> (lb-in <sup>2</sup> / kg-m <sup>2</sup> )	Weight Change per Length (lb-in / kg/m)	WR <sup>2</sup> Change per Length <sup>④</sup> (lb-in <sup>2</sup> /in / kg-m <sup>2</sup> /m)	Continuous Torque @ 1.0 S.F. (lb-in / Nm)	Continuous Torque @ 2.0 S.F. (lb-in / Nm)	Peak Overload Torque (lb-in / Nm)
350.275	F	13.8 / 6.2	32 / 0.0093	0.07 / 1.5	0.13 / 0.0015	3,617 / 408	1,808 / 204	5,425 / 613
	A			0.06 / 1.2	0.11 / 0.0013			
	R			0.06 / 1.1	0.10 / 0.0012			
375.275	F	13.8 / 6.2	32 / 0.0093	0.07 / 1.5	0.13 / 0.0015	5,311 / 600	2,660 / 300	7,967 / 900
	A			0.06 / 1.2	0.11 / 0.0013			
	R			0.06 / 1.1	0.10 / 0.0012			
450.275	F	12.9 / 5.9	32 / 0.0092	0.07 / 1.5	0.13 / 0.0015	7,250 / 820	3,625 / 410	10,875 / 1229
	A			0.06 / 1.2	0.11 / 0.0013			
	R			0.06 / 1.1	0.10 / 0.0012			
	X			0.06 / 1.2	0.10 / 0.0012			
485.338	F	23.4 / 10.6	47 / 0.014	0.09 / 1.8	0.24 / 0.0029	11,000 / 1243	5,500 / 621	16,500 / 1864
	A			0.08 / 1.5	0.21 / 0.0024			
	R			0.07 / 1.4	0.19 / 0.22			
485.425	R	24.0 / 10.9	74 / 0.022	0.09 / 1.7	0.38 / 0.0044	11,000 / 1243	5,500 / 621	16,500 / 1864
	X			0.09 / 1.8	0.39 / 0.0045			
485.625	R	26.5 / 12.0	92 / 0.027	0.13 / 2.6	1.2 / 0.015	11,000 / 1243	5,500 / 621	16,500 / 1864
	A			0.10 / 1.9	0.42 / 0.0049			
	R			0.089 / 1.7	0.38 / 0.0044			
650.425	X	31.5 / 14.3	122 / 0.036	0.092 / 1.8	0.39 / 0.005	18,100 / 2045	9,050 / 1022	27,150 / 3067
	R			0.13 / 2.6	1.2 / 0.014			
	X			0.14 / 2.7	1.3 / 0.015			
650.625	R	34.4 / 15.6	141 / 0.041	0.13 / 2.6	1.2 / 0.014	18,100 / 2045	9,050 / 1022	27,150 / 3067
	X			0.14 / 2.7	1.3 / 0.015			
	R			0.18 / 3.4	2.9 / 0.033			
650.825	X	37.9 / 17.2	194 / 0.056	0.18 / 3.6	3.0 / 0.035	18,100 / 2045	9,050 / 1022	27,150 / 3067
	A			0.15 / 2.9	1.4 / 0.016			
	R			0.13 / 2.6	1.2 / 0.014			
850.625	X	63.6 / 28.8	440 / 0.130	0.14 / 2.7	1.3 / 0.015	36,200 / 4090	18,100 / 2045	54,300 / 6135
	R			0.18 / 3.4	2.9 / 0.033			
	X			0.18 / 3.6	3.0 / 0.035			
850.825	R	68.5 / 31.0	512 / 0.15	0.18 / 3.4	2.9 / 0.033	36,200 / 4090	18,100 / 2045	54,300 / 6135
	X			0.18 / 3.6	3.0 / 0.035			
850.1025	X	74.8 / 33.9	657 / 0.19	0.23 / 4.4	5.8 / 0.067			
850.1275	X	78.4 / 35.6	768 / 0.22	0.28 / 5.5	11.3 / 0.13			

① All dimensional values are subject to change without notice.

② F=Fiberglass; A=Amalgamation; R=Standard Carbon Fiber; X=Special Carbon Fiber.

③ 850 Series couplings may use either of two standard hub styles.

④ The standard weight and WR<sup>2</sup> values are at minimum DBSE and standard minimum bore for a complete assembly. To determine the total weight or inertia, subtract the minimum DBSE from the total DBSE required and multiply that value times the WT and/or WR<sup>2</sup> change per length, then add that calculated WT or WR<sup>2</sup> to the minimum DBSE values. Values may vary slightly depending on the actual bore and key size.



## Rexnord Cooling Tower Backstop

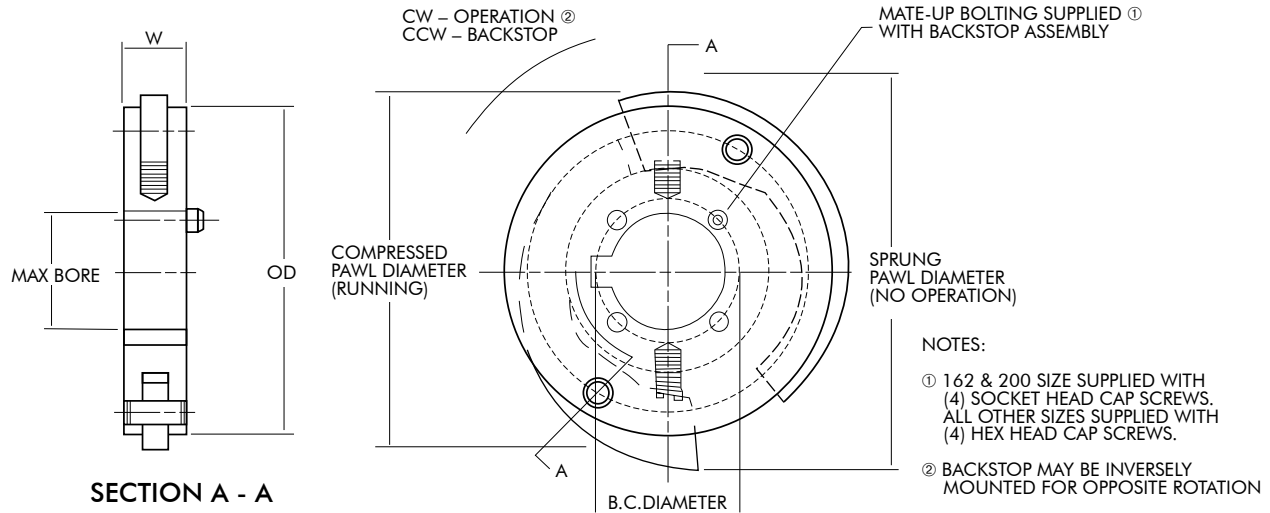

### Bolt-On Backstop Tabulation

Model	Mating Hub Backstop Bolting Information			OD (in / mm)	W (Ref) (in / mm)	Pawl Diameter (Ref)		Compressed Speed (RPM Ref)
	B. C. Diameter (in / mm)	Hole Diameter (in / mm)	Tightening Torque (lb-in / Nm)			Compressed (in / mm)	Sprung (in / mm)	
350/375/450	3.500 / 88.9	0.3125 / 7.938	40 / 4.5	9-1/16 / 230.2	1-1/8 / 28.6	9-3/16 / 233.4	10-9/16 / 268.3	400 RPM Ref
485	4.063 / 103.2	0.3125 / 7.938	142 / 16.0					
650	4.625 / 117.5	0.3750 / 9.525	225 / 25.4					
850	4.875 / 123.8	0.5000 / 12.700	350 / 39.5					

## Addax Cooling Tower Brake



The Addax Cooling Tower Brake is a mechanical, manually-actuated caliper disc brake for stopping, holding and locking out cooling tower fans. It easily adapts to the motor hub of the Addax Composite Coupling.

### Safety

- Simply engage the Addax Cooling Tower Brake to safely stop the fan
- No need for ropes, 2 x 4s or lassoing the fan
- Capable of being locked out according to safety standards for lockout/tagout
- A more reliable means for controlling the potential for fan free-wheeling
- Allows employees to be in direct control of fan free-wheeling during maintenance activities
- All actuation done outside of guards

### Protection from windmilling

- In case of high winds, the fan can be locked down in seconds
- Time and expense saved in preparing for plant lock-down
- No more fan or stack damage

# Engineering Data

## Driveshaft Vibration Caused by Blade Pass Frequency (BPF)

Lateral Natural Frequency (LNF) relates to beam stiffness and mass of the composite coupling. All beams have a natural frequency. The Rexnord Addax driveshaft is a long, slender beam that has an LNF commonly referred to as critical speed. Critical speed of the shaft is calculated in SelectC 2007 and is supplied to our customers. Blade pass frequency (BPF) is the number of blades multiplied by the fan speed. Fan blades in a cooling tower induce a forcing frequency caused by pressure pulsations on adjacent components including the driveshaft.

Blade pass vibration is caused by pressure pulsations on the driveshaft when the shaft's natural frequency is coincident with the fan BPF. When the driveshaft is experiencing a blade pass harmonic, sometimes it can be seen bouncing out of plane. This shaft vibration usually manifests itself in the motor and gearbox. Shaft natural frequency and BPF must be designed 8% away to have assurance there is no overlap. Rexnord Addax shafts exhibit minimal vibration contributing to the overall spectrum. Additionally, gear mesh frequency can be heard resonating from the driveshaft, however this is typically at a much higher frequency magnitude than BPF.

The Cooling Technology Institute (CTI) recommends a 1.15 factor — critical speed over maximum operating speed. Prior to 2011, CTI recommended a 1.30 safety margin. The 1.30 factor was established before composite shafts, when only steel driveshafts were available. Steel shafting is massive, deflects from thermal growth, less predictable and potentially dangerous when approaching critical speed. Composite shafts are less than 1/3 the mass of steel and dimensionally stable. As composite shafts offer 1/3 less mass, the deflection magnitude is significantly less than steel and safe when approaching critical speed. Rigorous testing has proven that a 1.3 margin is not required for composite shafting and CTI dropped their recommendation to a 1.15 margin. Each Addax shaft size and material type is tested. Manufacturing variability accounts for less than  $\pm 3\%$  of the variability in the shaft's LNF. It is not recommended to use a 1.15 safety factor when purchasing shafts from other manufacturers, due to possible excessive manufacturing variability. Manufacturing variability of the Addax shaft accounts for less than  $\pm 3\%$  of the variability in the shaft's LNF. These facts demonstrate that a 15% safety margin over operating speed is adequate for safe driveshaft operation.

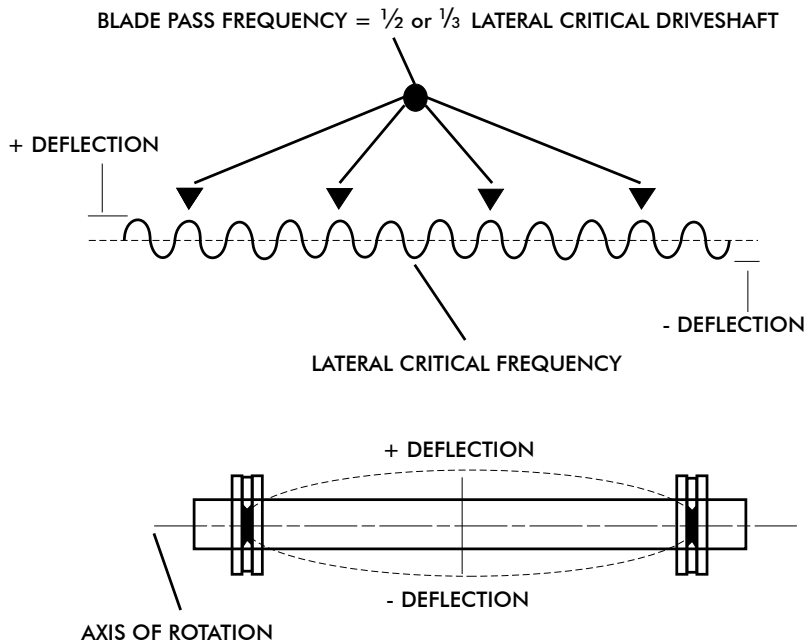





*js International Corp.*

Kolon Digital Tower Villant, Suite #707  
30, Digital-Ro 32-Gil, Guro-Gu,  
Seoul (08390), KOREA  
Tel: 2103-5050 / Fax: 2103-5055  
Web: [www.jsinternational.net](http://www.jsinternational.net)  
e-mail: [jsikorea@jsinternational.net](mailto:jsikorea@jsinternational.net)



**rexnord.com**

Contact us — visit [rexnord.com/contact](http://rexnord.com/contact)

APPLICATION CONSIDERATIONS

The proper selection and application of products and components, including the related area of product safety, is the responsibility of the customer. Operating and performance requirements and potential associated issues will vary appreciably depending upon the use and application of such products and components. The scope of the technical and application information included in this publication is necessarily limited. Unusual operating environments and conditions, lubrication requirements, loading supports, and other factors can materially affect the application and operating results of the products and components and the customer should carefully review its requirements. Any technical advice or review furnished by Regal Beloit America, Inc. and/or its affiliates ("Regal") with respect to the use of products and components is given in good faith and without charge, and Regal assumes no obligation or liability for the advice given, or results obtained, all such advice and review being given and accepted at customer's risk.

For a copy of our Standard Terms and Conditions of Sale, please visit <https://www.regalbeloit.com/Terms-and-Conditions-of-Sale>. These terms and conditions of sale, disclaimers and limitations of liability apply to any person who may buy, acquire or use a Regal product referred to herein, including any person who buys from a licensed distributor of these branded products.